

Features

Supports a 2x2 arrangement of the Ketek PA3325-WB-0808 8x8 array of 3mm SiPMs for a total of 16x16 SiPMs

Horizontal signal connectors located on the back, array located on the front

4-side tileable installation

Hybrid multiplexed readout

Four encoded position signals for event centroid calculations: X+, X-, Y+, Y-

16 row signals and 16 column signals

DC-coupled signal path

Low power consumption

Patented diode-coupled charge division readout, superior to traditional resistive readout

Improved spatial uniformity

Faster rise time

Reduced image noise

Precision temperature sensor

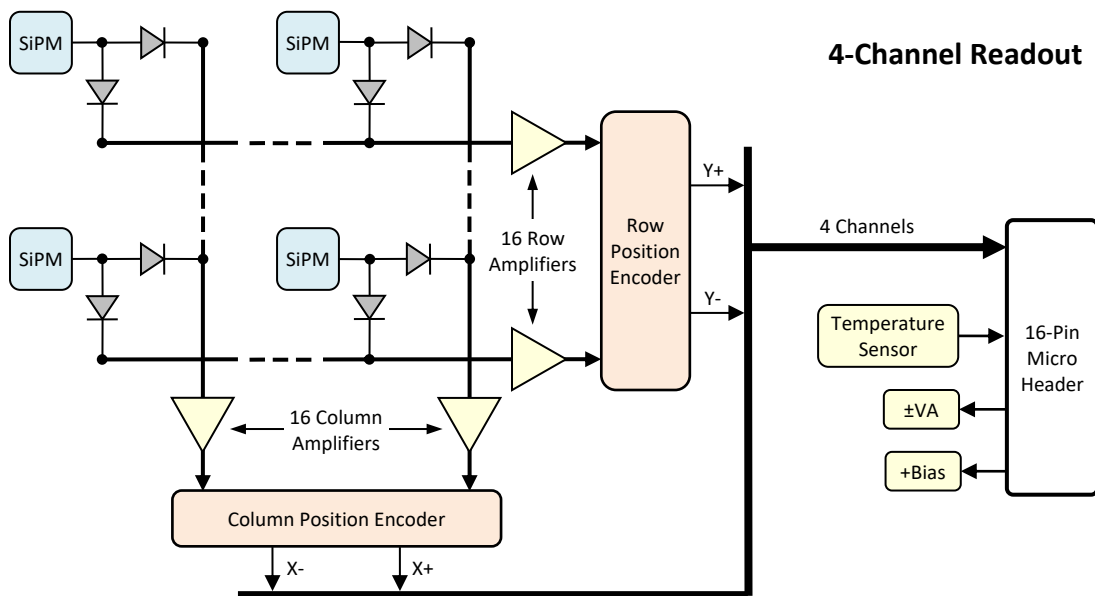
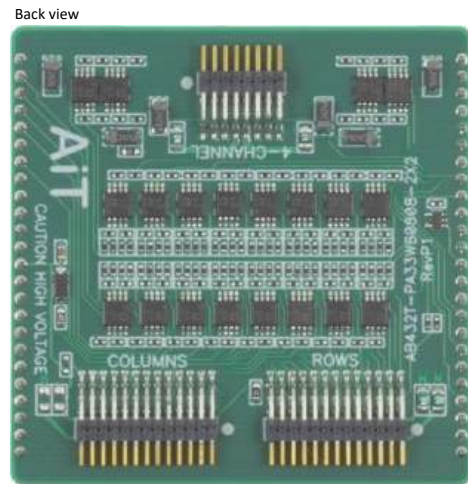
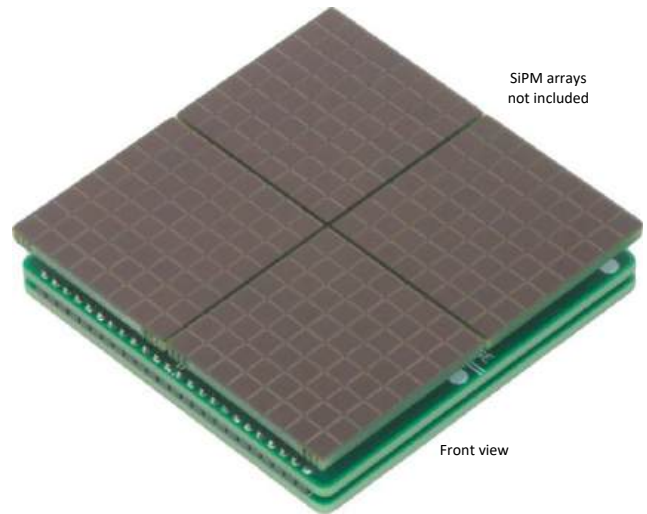

4-Channel Readout Specifications

Position Signal Outputs

Samtec FFSD-08-D-XX.XX-01-N
(XX.XX = length in inches)

Channel Map

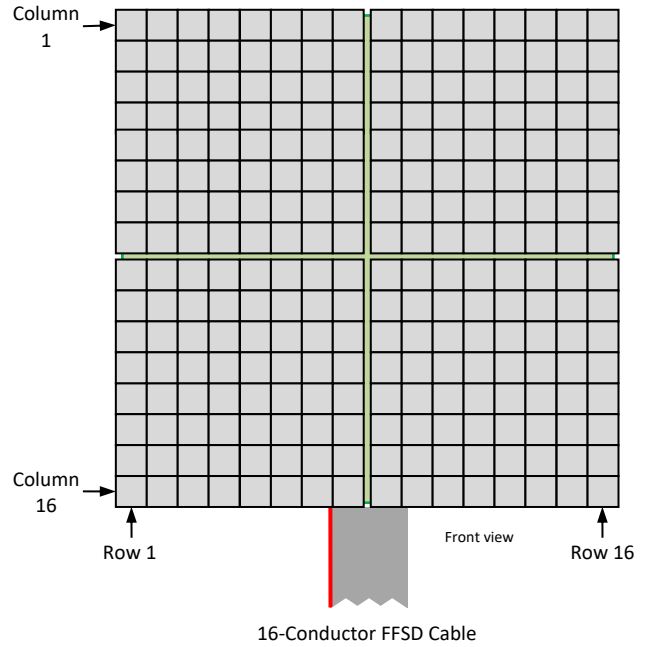

Signal Connector

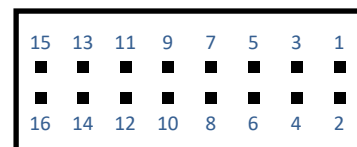

Side View

Pin	Function	Pin	Function
1	Temperature	2	Ground
3	X-	4	Ground
5	X+	6	Ground
7	-VA	8	Ground
9	+VA	10	Ground
11	Y-	12	Ground
13	Y+	14	Ground
15	+Bias	16	Ground

Row and Column Encoder Weights

Row# or Col# (for X- or Y-)	Row# or Col# (for X+ or Y+)	Fraction ideal	Fraction actual	% Error	Notes
1	16	0.0625	0.0625	0.00 %	Sum of X- and X+ fractions = 1.0625 Independent of signal position
2	15	0.1250	0.1250	0.00 %	
3	14	0.1875	0.1861	-0.75 %	
4	13	0.2500	0.2483	-0.68 %	
5	12	0.3125	0.3158	1.06 %	
6	11	0.3750	0.3731	-0.51 %	
7	10	0.4375	0.4412	0.85 %	
8	9	0.5000	0.5000	0.00 %	
9	8	0.5625	0.5618	-0.12 %	
10	7	0.6250	0.6250	0.00 %	
11	6	0.6875	0.6818	-0.83 %	
12	5	0.7500	0.7500	0.00 %	
13	4	0.8125	0.8021	-1.28 %	
14	3	0.8750	0.8876	1.44 %	
15	2	0.9375	0.9375	0.00 %	
16	1	1.0000	1.0000	0.00 %	

Note: Errors exclude component tolerances

Output Signals

$X^- = (\text{SiPM signal}) * (\text{encoder gain}) * (X^- \text{ fraction})$
 $X^+ = (\text{SiPM signal}) * (\text{encoder gain}) * (X^+ \text{ fraction})$
 $Y^- = (\text{SiPM signal}) * (\text{encoder gain}) * (Y^- \text{ fraction})$
 $Y^+ = (\text{SiPM signal}) * (\text{encoder gain}) * (Y^+ \text{ fraction})$

Typical event position calculation:

X column = $(X^+ - X^-) / (X^+ + X^-)$
Y row = $(Y^+ - Y^-) / (Y^+ + Y^-)$

Example

SiPM signal at column 4, row 3 (excluding encoder gain)

$X^- = (\text{Column 4 signal}) * 0.2483$
 $X^+ = (\text{Column 4 signal}) * 0.8021$
 $Y^- = (\text{Row 3 signal}) * 0.1861$
 $Y^+ = (\text{Row 3 signal}) * 0.8876$

Row and Column Readout Specifications

Position Signal Outputs

Encoding	Charge division multiplexed to 16 rows and 16 columns
Gain	750Ω transimpedance gain
Output voltage	0 → -1V into 100Ω
Output impedance	100Ω
Output current	50mA maximum

Temperature Sensor

Output voltage	500mV + 10mV per °C
Output current	10mA
Output impedance	100Ω
Accuracy	±0.5°C

Bias Voltage

	+29V typical (refer to SiPM data)
Voltage clamp	47V Zener diode 500mW maximum

Amplifier Voltage (±VA)

	±2.8V → ±5.5V DC maximum
Current	±70mA typical at ±5.0V (I _q , no signal, no load)

Samtec FFSD-13-D-XX.XX-01-N
(XX.XX = length in inches)

Channel Map

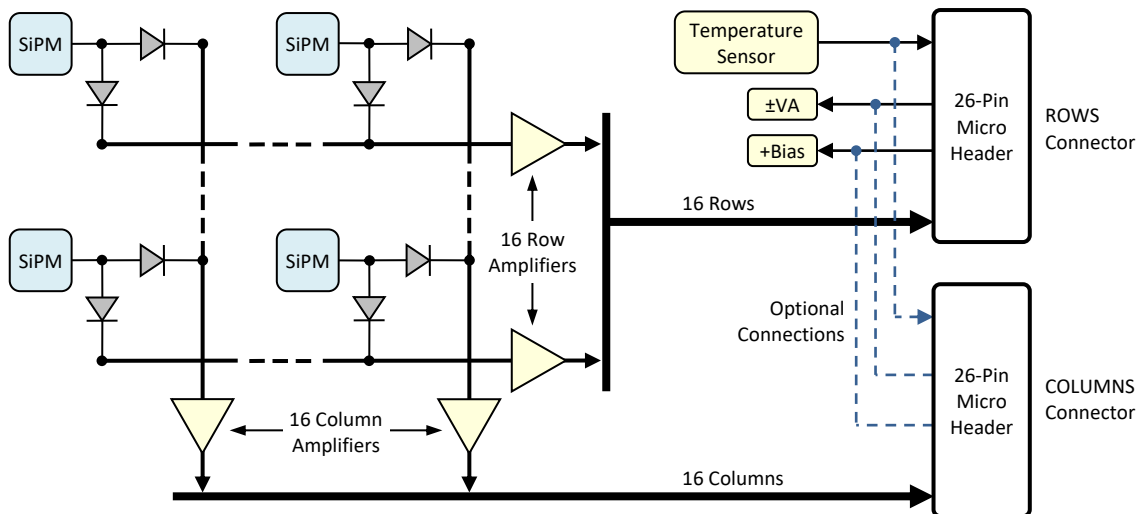
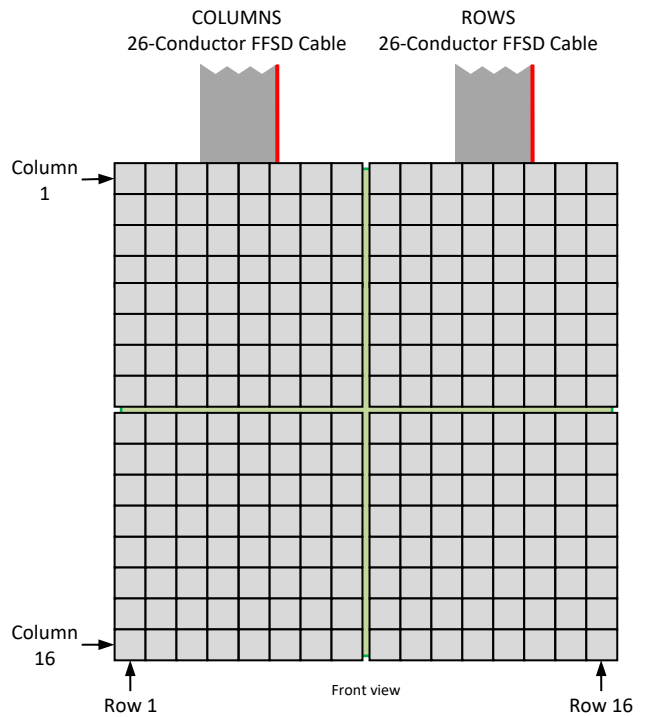

Row and Column Signal Connectors

ROWS

26-pin 0.050" horizontal header

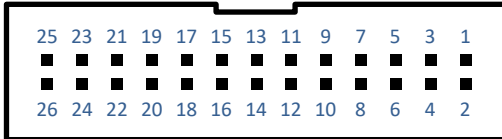

Side View

Pin	Function	Pin	Function
1	Row 1	2	Temperature
3	Row 2	4	Ground
5	Row 4	6	Row 3
7	Row 5	8	Ground
9	Row 6	10	Row 7
11	Row 8	12	-VA
13	Row 9	14	Ground
15	Row 10	16	+VA
17	Row 12	18	Row 11
19	Row 13	20	Ground
21	Row 14	22	Row 15
23	Row 16	24	Ground
25	+Bias	26	Ground

COLUMNS

26-pin 0.050" horizontal header

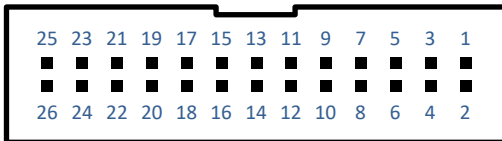

Side View

Pin	Function	Pin	Function
1	Column 1	2	Temperature
3	Column 2	4	Ground
5	Column 4	6	Column 3
7	Column 5	8	Ground
9	Column 6	10	Column 7
11	Column 8	12	*NC (-VA)
13	Column 9	14	Ground
15	Column 10	16	*NC (+VA)
17	Column 12	18	Column 11
19	Column 13	20	Ground
21	Column 14	22	Column 15
23	Column 16	24	Ground
25	*NC (+Bias)	26	Ground

NOTE

+Bias, +VA, -VA are normally connected to the ROWS connector. These signals are not connected to the COLUMNS connector. Disconnected signals are indicated as "NC". These signals can be optionally connected to the COLUMNS connector as an assembly variant.

Typical Signals

4-Channel Readout

Source = Laser; Receiver = ABR4, channel 1, minimum gain; Bias = +29V; FFSD cable = 36"

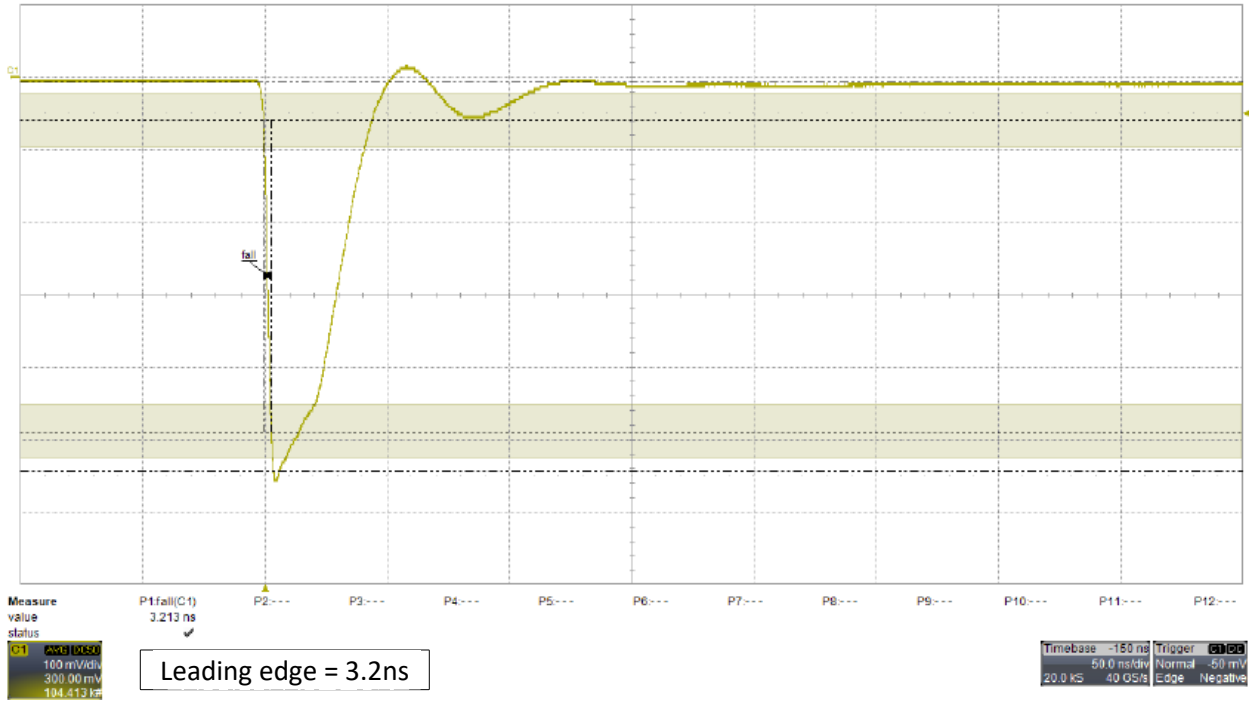

Source = LYSO emission; Receiver = ABR4, channel 1, minimum gain; Bias = +30V; FFSD cable = 36"; persistence display

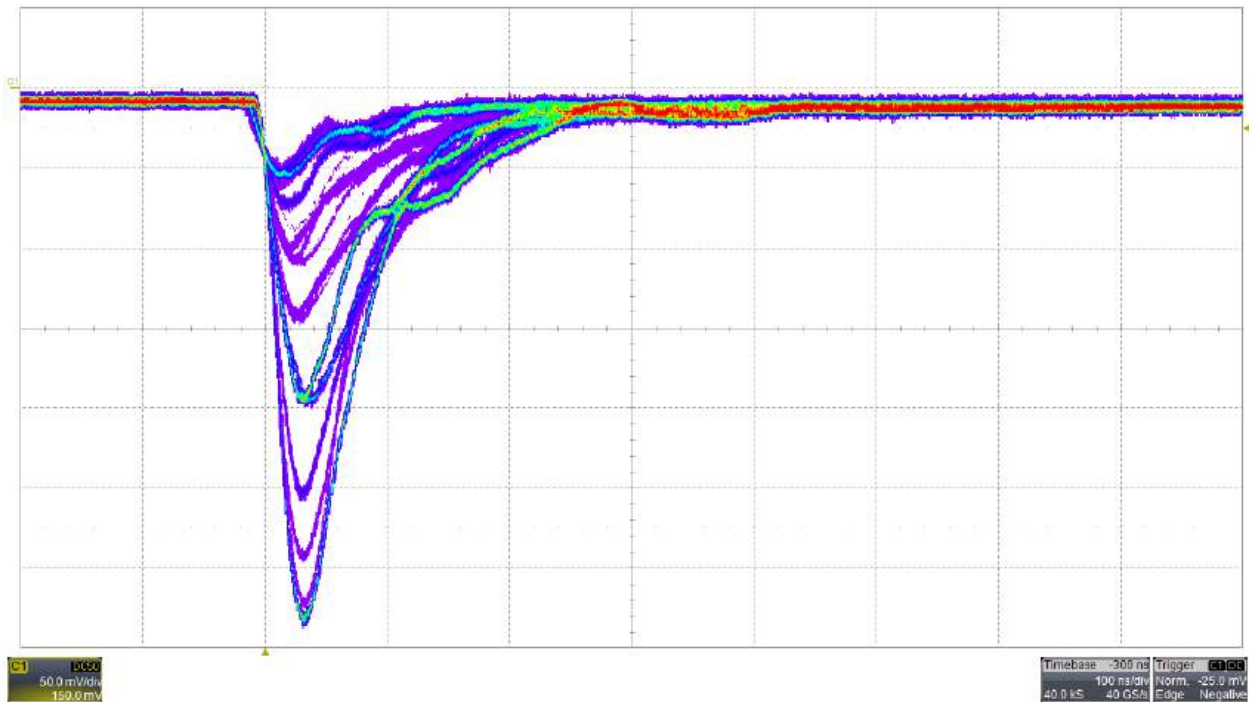

Typical Signals

Row and Column Readout (rows connector)

Source = Laser; Receiver = ABR16, channel 10, minimum gain; Bias = +29V; FFSD cable = 12"

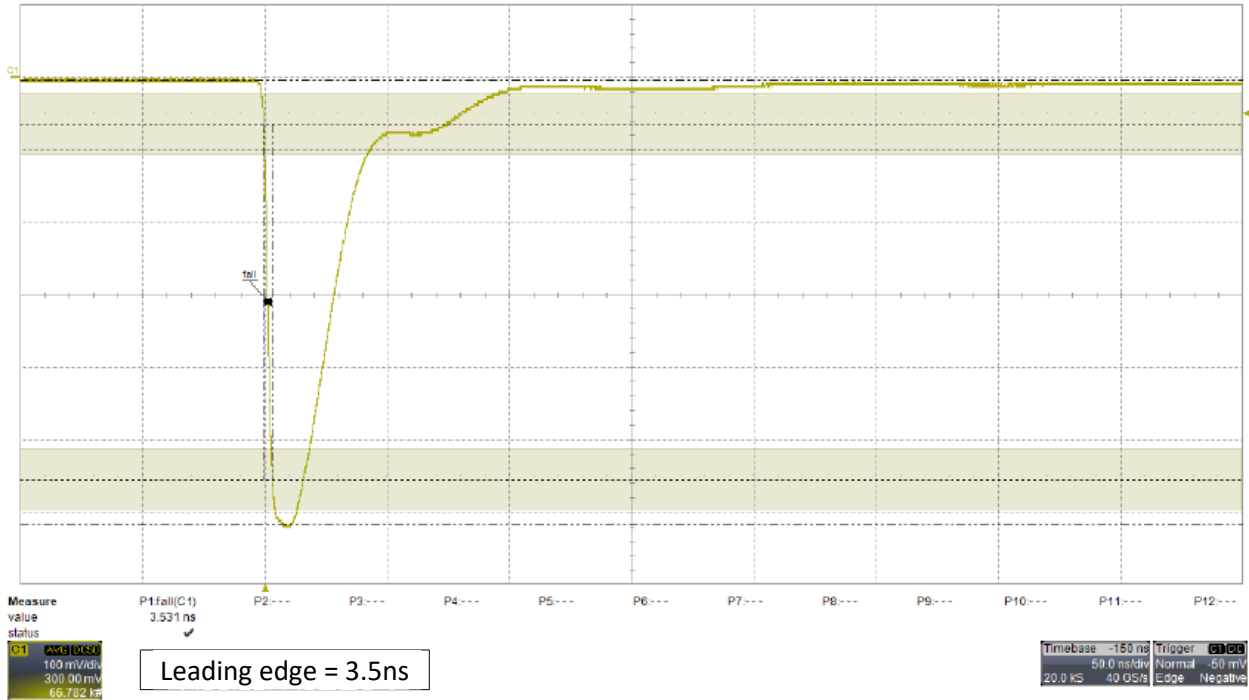

Source = LYSO emission; Receiver = ABR16, channel 10, minimum gain; Bias = +29V; FFSD cable = 12"; persistence display

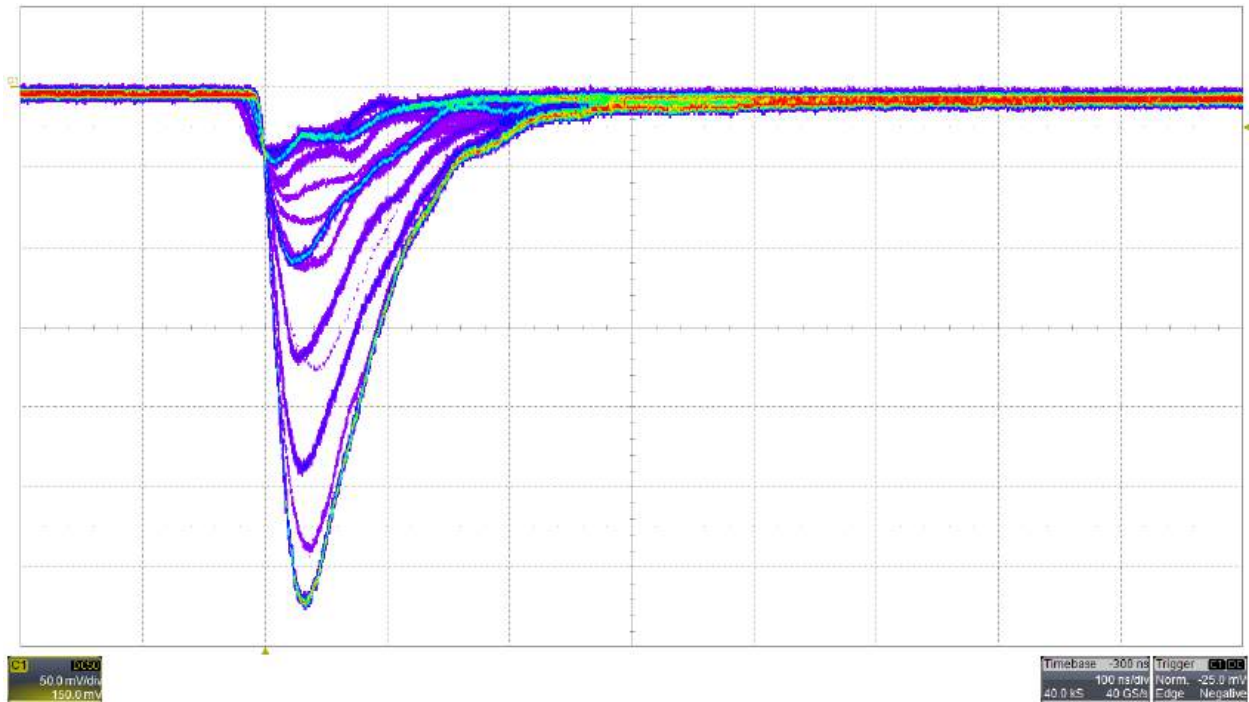

Mechanical

Front View

53.8mm (2.12")

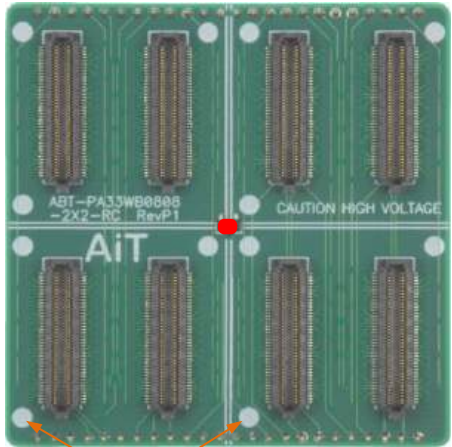

SiPM Array
Alignment Marks

53.8mm
(2.12")

● Temperature sensor
Measurement tolerance: $\pm 0.020''$

Back View

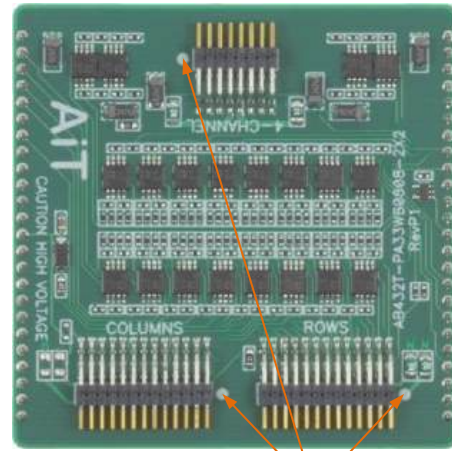

Align pin 1 with the
red conductor on the
Samtec FFSD cable

Side View, Base Attached to Arrays

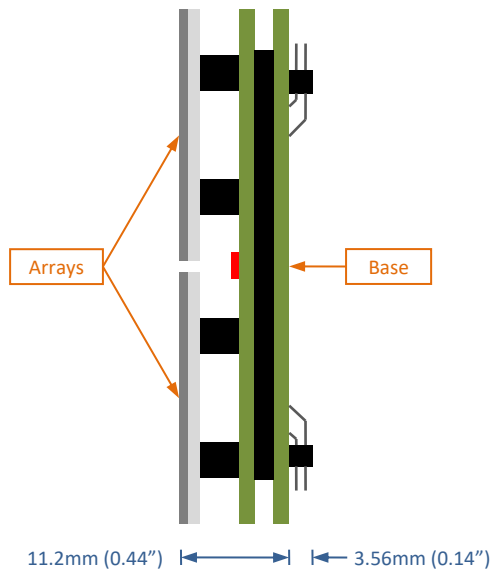

Array Locations

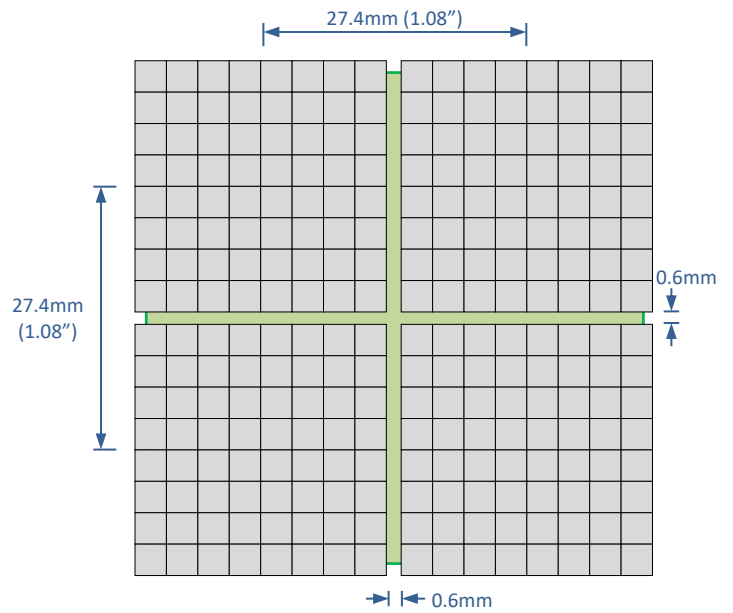

Array Installation Guide

STEP 1

Install the first array by carefully pressing on the array surface above the connectors until the array is firmly seated.

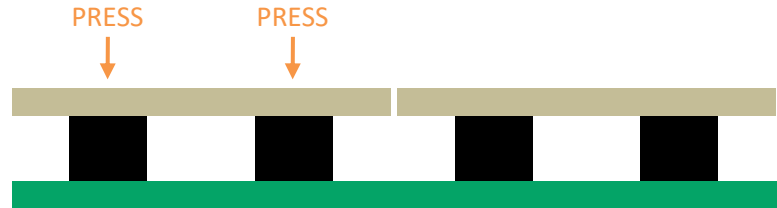

CAUTION: Do not contact the glass surface with any hard object. Any contact will damage the glass.

STEP 2

Attach the second array by carefully pressing above the outer connector until the connector is firmly seated.

Do not press the inner connector first or the glass surfaces may touch and damage the glass.

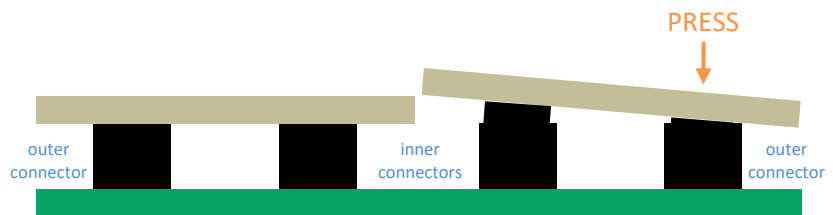

CAUTION: Do not contact the edges of the arrays with each other. Any contact will damage the glass.

STEP 3

Press above the inner connector until the second array is firmly seated.

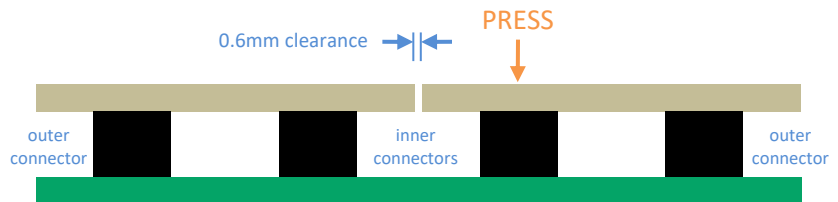

Array Removal

To remove the arrays, reverse the installation procedure. Pull up the connectors labeled **PRESS**. Always pull up the inner connectors first.

WARNING

Never insert the inner connectors first, or remove the outer connectors first. If this occurs, the glass surfaces will touch and may damage the arrays.

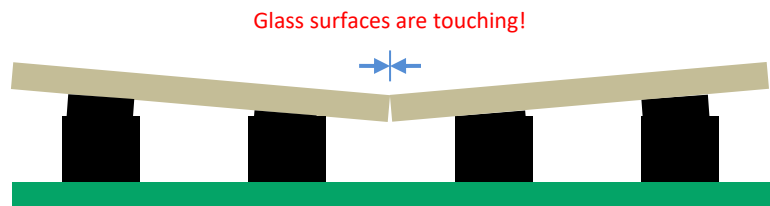

Never insert inner connectors first
Never pull up outer connectors first

4-Channel Active Base Readout Kit

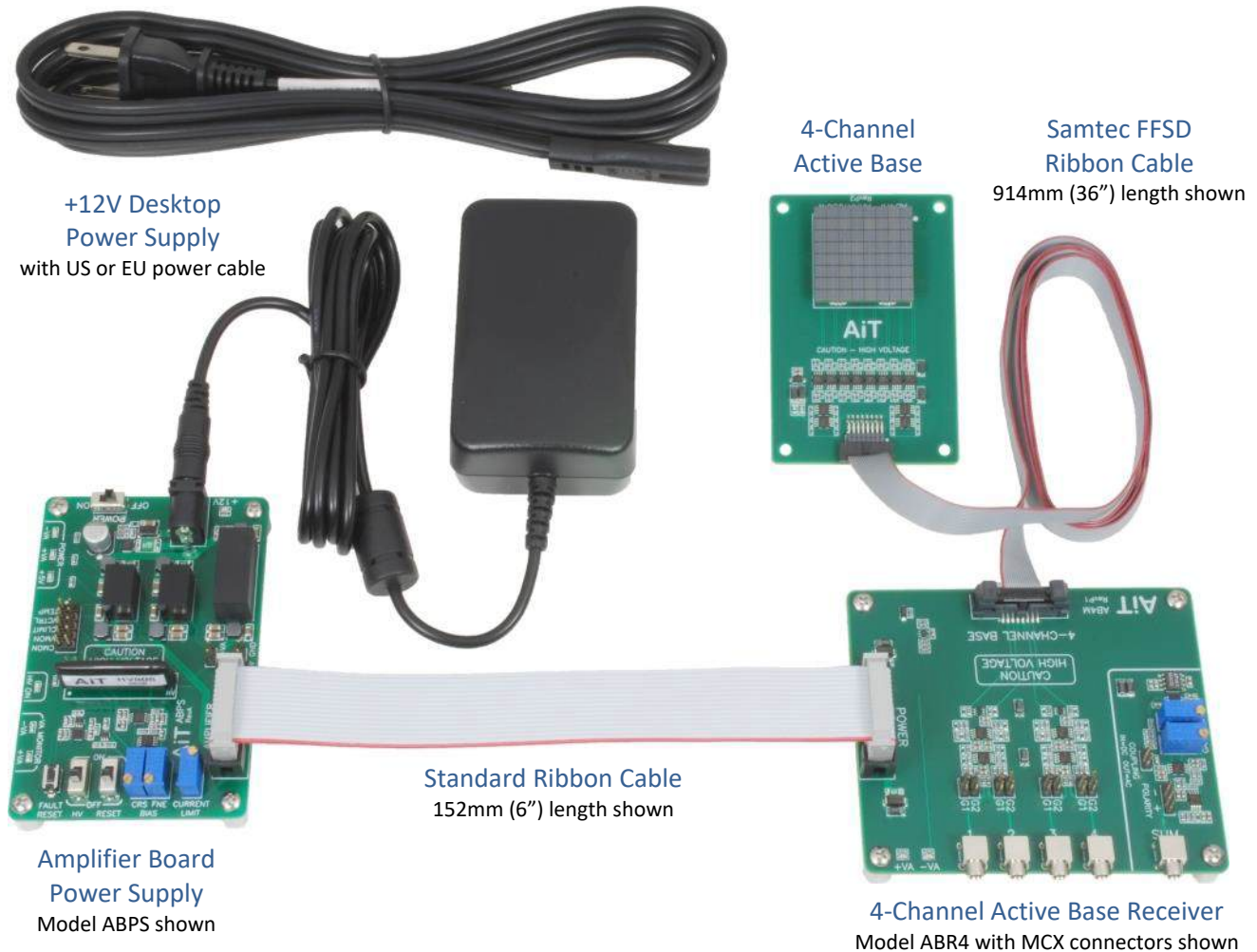

+12V Desktop
Power Supply
with US or EU power cable

4-Channel
Active Base

Samtec FFSD
Ribbon Cable
914mm (36") length shown

Standard Ribbon Cable
152mm (6") length shown

Amplifier Board
Power Supply
Model ABPS shown

4-Channel Active Base Receiver
Model ABR4 with MCX connectors shown

Components

Each component is available separately. Refer to each datasheet for details.

The Active Base includes a 914mm (36") Samtec FFSD micro-pitch ribbon cable.

The Amplifier Board Power Supply includes a 12V desktop power supply and a HV80 bias voltage power supply.

The 4-channel Active Base Receiver includes a 152mm (6") power supply ribbon cable and a breakout board to connect any external power supply.

16-Channel Active Base Readout Kit

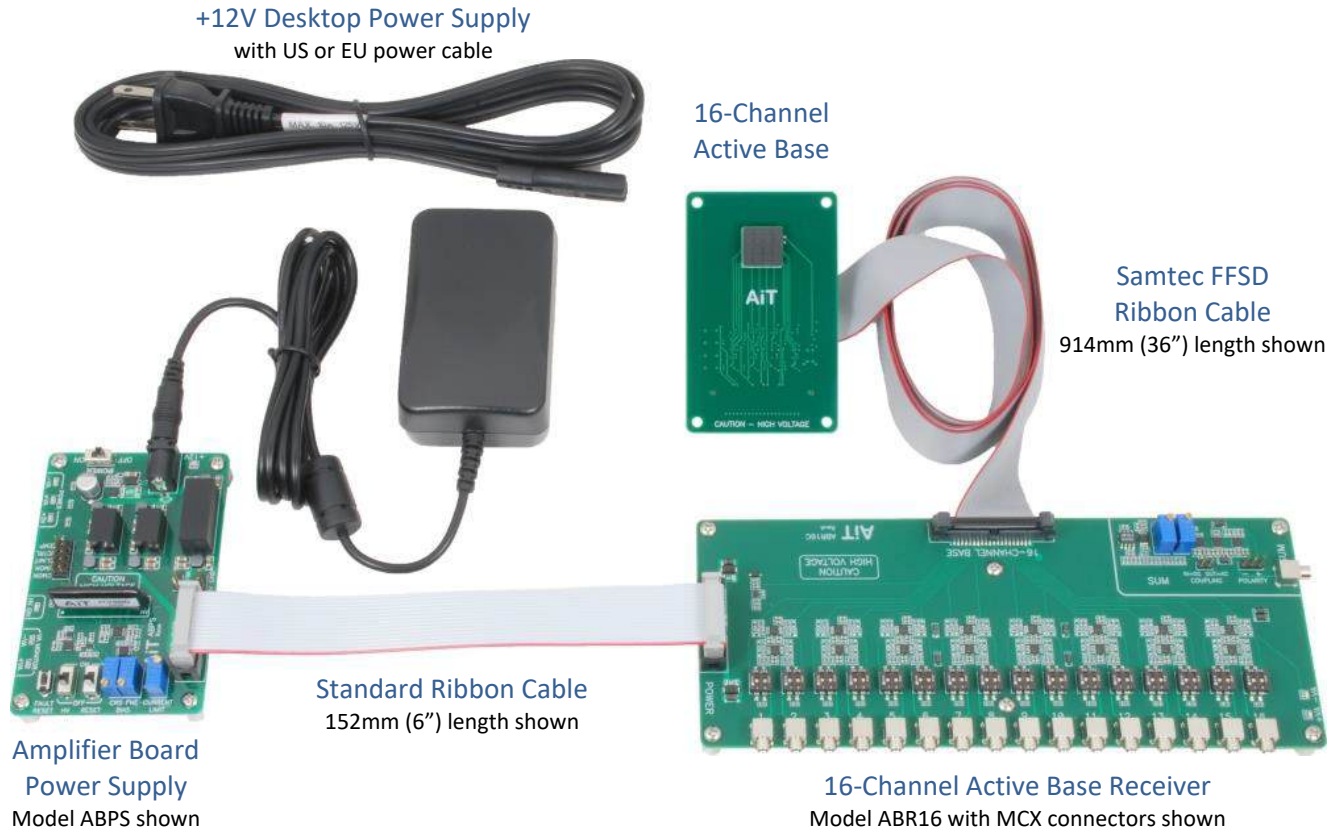

Components

Each component is available separately. Refer to each datasheet for details.

The Active Base includes a 914mm (36") Samtec FFSD micro-pitch ribbon cable.

The Amplifier Board Power Supply includes a 12V desktop power supply and a HV80 bias voltage power supply.

The 16-channel Active Base Receiver includes a 152mm (6") power supply ribbon cable and a breakout board to connect any external power supply.

Safety Information



WARNING – High Voltage

High voltage may be present during operation
High voltage stored on capacitors may be present after power is removed
Improper handling may result in personnel injury or equipment damage

This high-voltage device must be used only by personnel trained and qualified in safe handling, installation, and operation of high-voltage equipment.



CAUTION – Electrostatic Discharge (ESD) Sensitivity

The circuit board can be damaged by electrostatic discharge. Observe precautions for handling electrostatic sensitive devices. Handle only at static-safe workstations.

High-Gain Photodetectors

High-gain photodetectors such as silicon photomultipliers may conduct damaging currents if exposed to high optical signal levels while the bias voltage is applied, or if the bias voltage exceeds the recommended operating range. These devices must be operated only in low-light conditions, and only within the manufacturer's recommended bias voltage range.

Handling and Disassembly

This product may be provided with a protective enclosure. Disassembled enclosure components and circuit boards may contain sharp edges. Take appropriate safety precautions while assembling or disassembling the enclosure and handling disassembled components.

Indoor Use Only

Do not operate this product in a wet or damp environment. Do not operate in an explosive atmosphere.

Use of this product, and AiT Instruments' liability related to use of this product, is further governed by AiT Instruments' standard terms and conditions of sale, which were provided upon purchase of this product.